

8 Typical Wall Section
SCALE 1:20

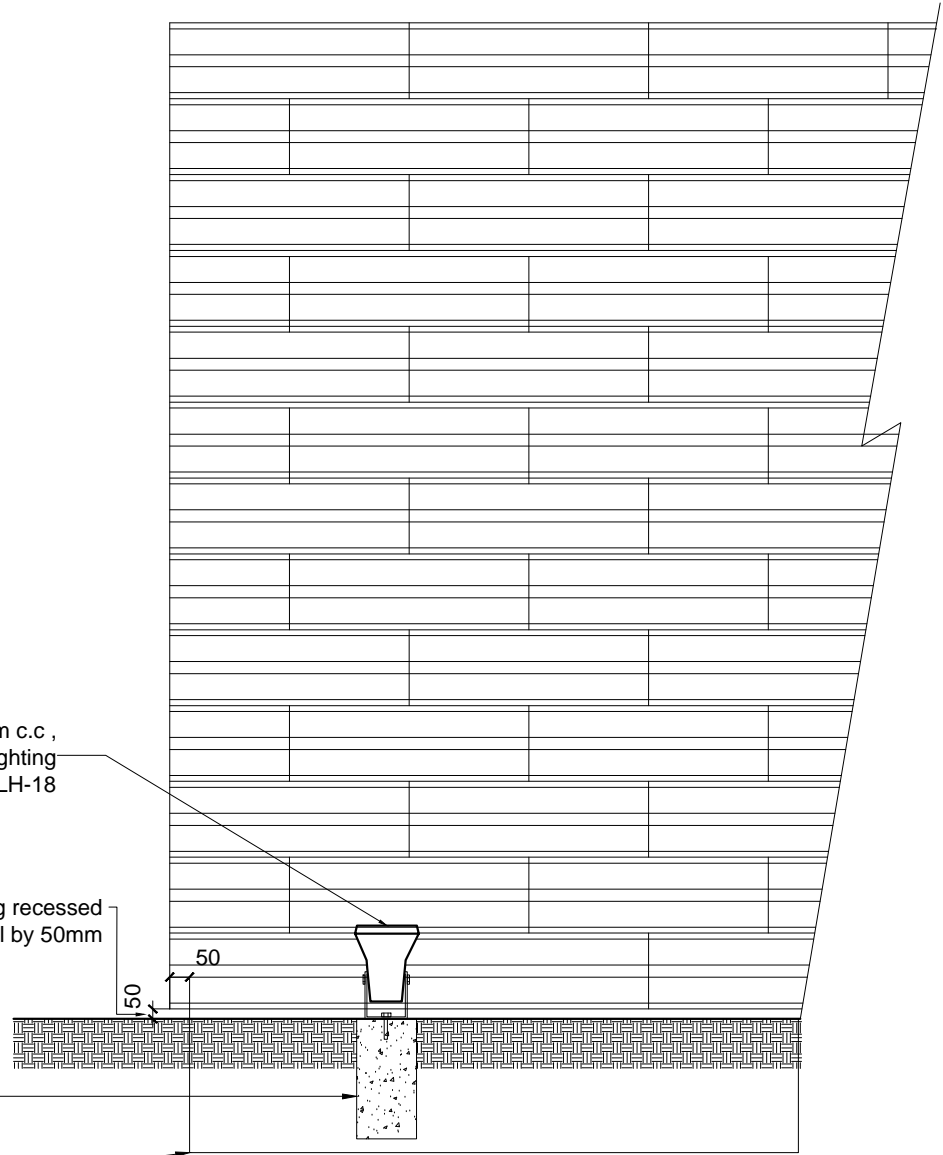

8a Typical Wall Elevation
SCALE 1:20

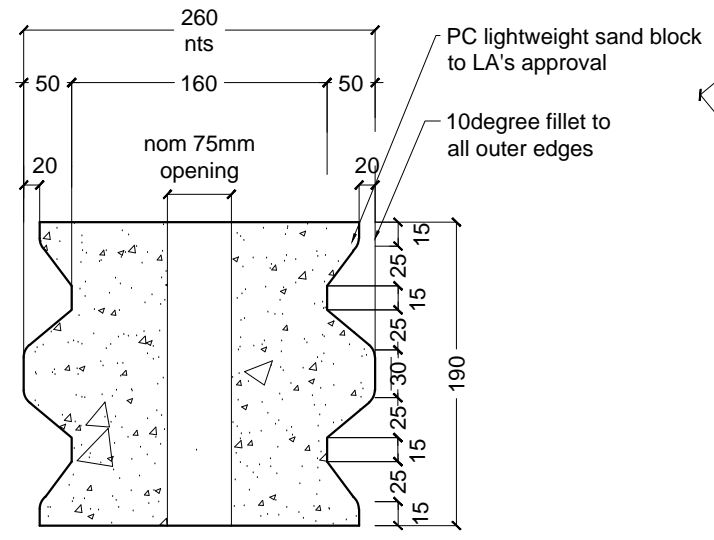

8b Typical Cement Block Section
INSET SCALE 1:5

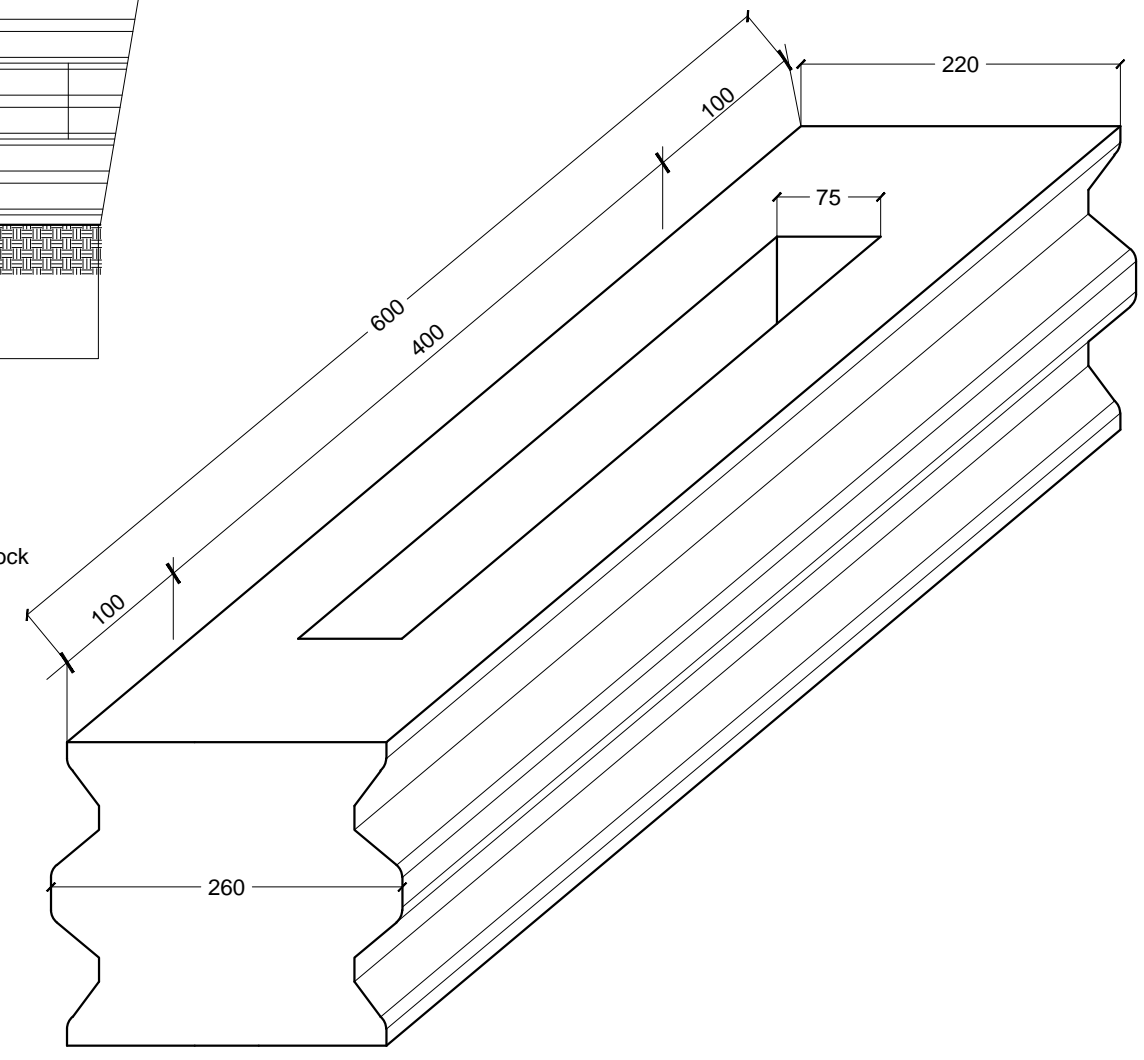

8c Axonometric
INSET SCALE 1:5