

TYPICAL FRONT ELEVATION

Scale 1:10

- Important Note:**
1. All mild steel to be hot dipped galvanised with metal anti-rust primer & paint to manufacturer's specification .
 2. all nuts & bolts to be stainless steel.
 3. All steel to be painted with micaceous iron paint colour: silver grey to LA's approval.

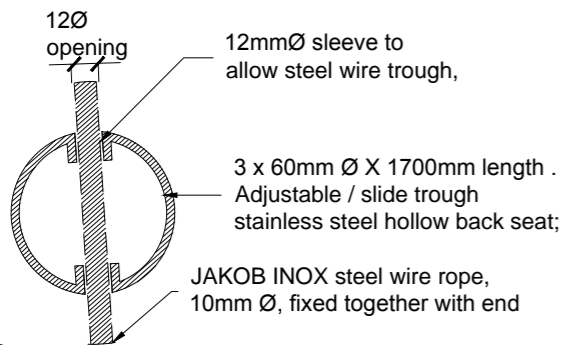

INSET A

Scale 1:3

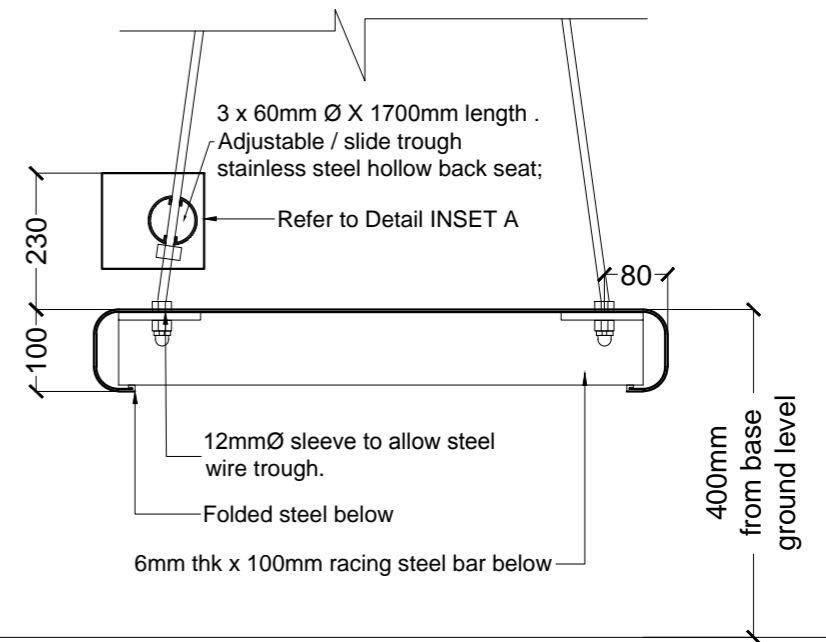
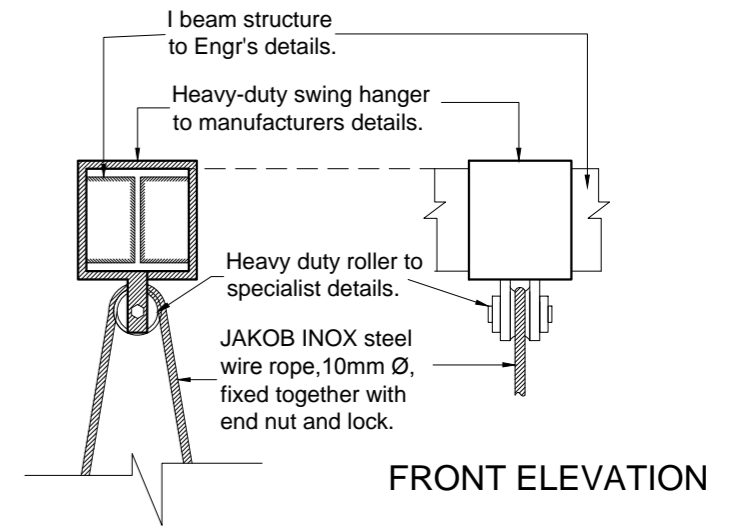

Scale 1:10

- Note:**
- All fittings shall be hot-dipped galvanized.
 - Swing hangers shall be fitted with an oil-impregnated broze bearing