

MP PLAN
Scale 1:50

*NOTE : STEEL MEMBERS AND SECTIONS TO BE GALVANISED and painted with MIO paint in graphite grey/ black. sample to be submitted first before proceeding with painting

perforated canvas roll shading device to detail

raised bamboo platform to detail. all bamboo used to be stained black to LA's approval

150x150x300 RC stump to engineer's detail. off-form finish to LA's specs

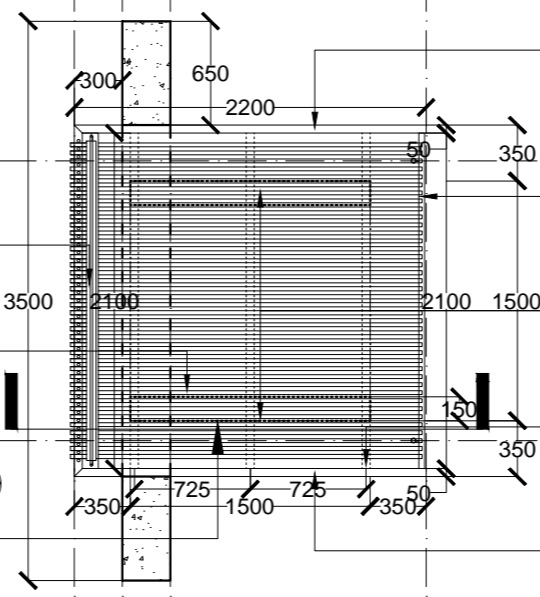

2.2m length 50x50mm L-angle, thickness 5mm frame welded to detail

30mm dia. bamboo pole stained black to brace SS frame

1.5x0.3m SS 50x50mm L-angle frame to support divan structure above

2.1m, 50x50mm SS RHS

2.2m length 50x50mm L-angle, thickness 5mm frame welded to detail

FORMWORK TO LA'S APPROVAL PRIOR TO CONSTRUCTION

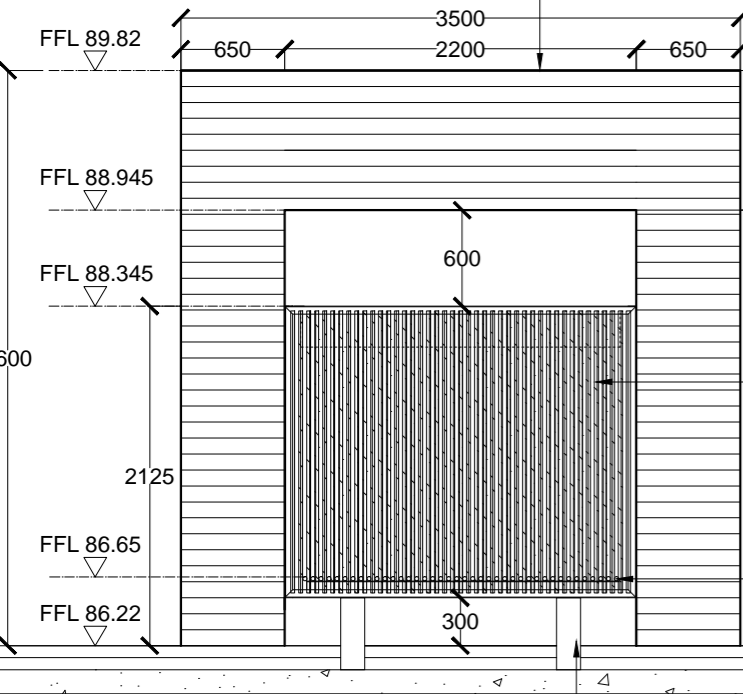

D1, D2, D3, D4 refer to dwg. MG-LD-22

screen detail 25mm dia. bamboo poles to LA's approval stained black fixed to SS frame to detail

raised platform detail 25mm dia. bamboo poles to LA's approval stained black fixed to SS frame to detail

2.1m, 50x50mm SS RHS

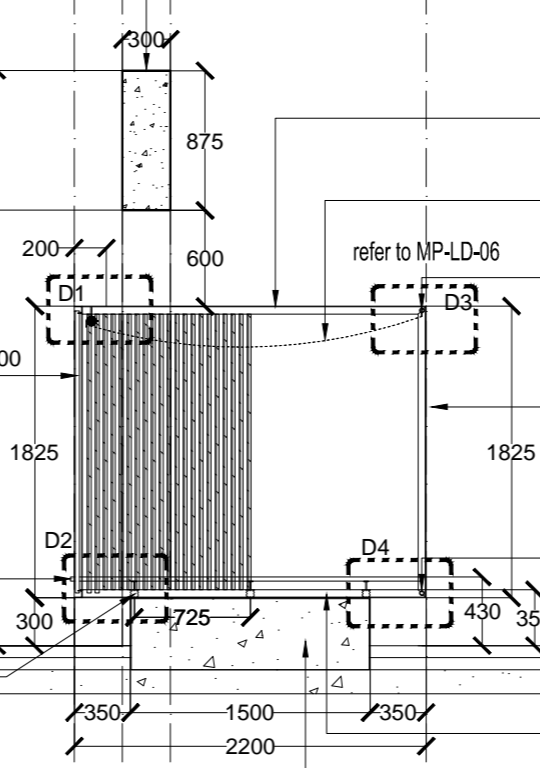

3.5x3.6x0.3m off-form concrete feature wall to engineer's spec. wall finish (concrete formwork finish) to LA's detail

2.2m length 50x50mm SS L-angle, thickness 5mm frame welded to detail

perforated canvas roll shading device to detail

30mm dia. bamboo pole stained black to brace SS frame

1.8m length 50x50mm SS L-angle, thickness 5mm frame welded to detail

30mm dia. bamboo pole stained black to brace SS frame

2.2m length 50x50mm L-angle, thickness 5mm frame welded to detail

1500x300x150 RC support stump to engineer's detail

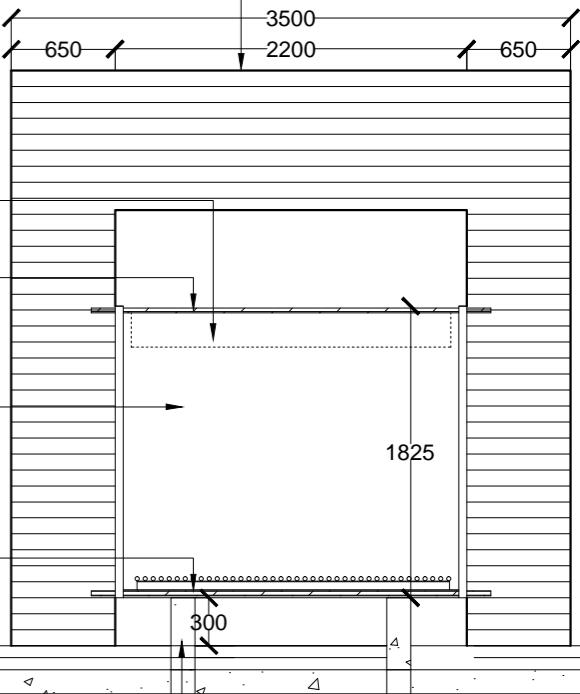

MP ELEVATION A
Scale 1:50

MP SECTION i
Scale 1:50

MP ELEVATION B
Scale 1:50