

Plan

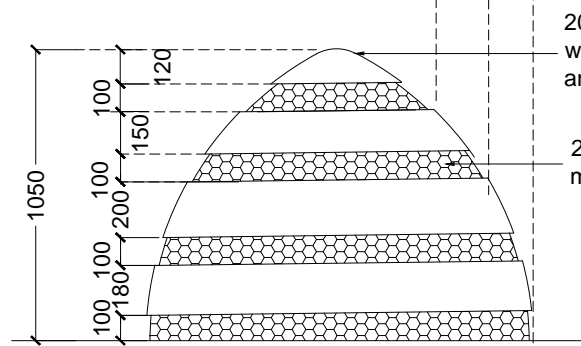

Typical Elevation

20mm thick smooth finished white plaster render to RC and brick infill structures.

20mm thk recessed decorative mosaic tiles to LA's approval

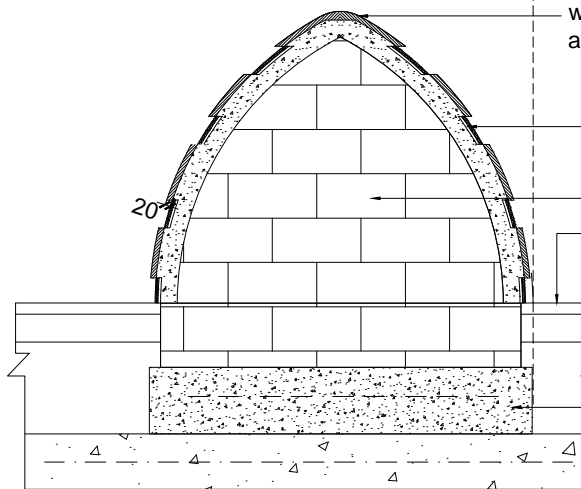

Typical Section

20mm thick smooth finished white plaster render to RC and brick infill structures.

20mm thk recessed decorative mosaic tiles to LA's approval

Brick structure to Engr's details.

40mm thk seamless matt

Footing to Engr's details.

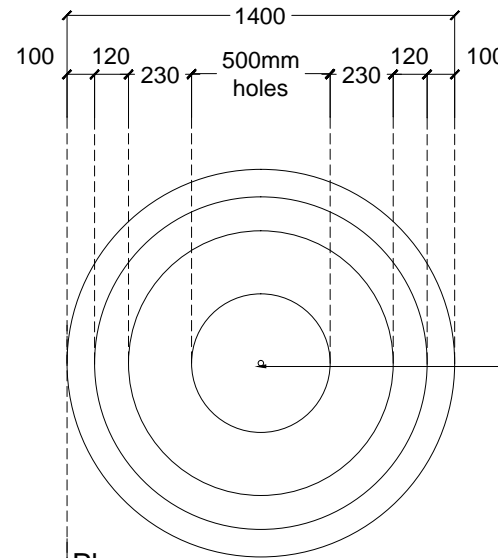

Plan

20mm Ø Outlet pipe with customized stainless steel grating cover. To LA's approval.

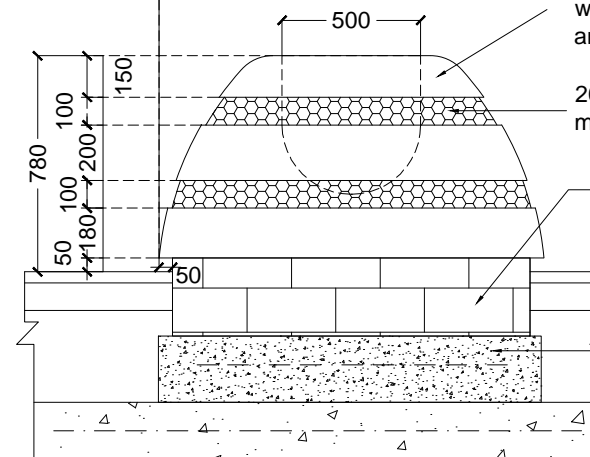

Typical Elevation

20mm thick smooth finished white plaster render to RC and brick infill structures.

20mm thk recessed decorative mosaic tiles to LA's approval

Brick structure to Engr's details.

Footing to Engr's details.

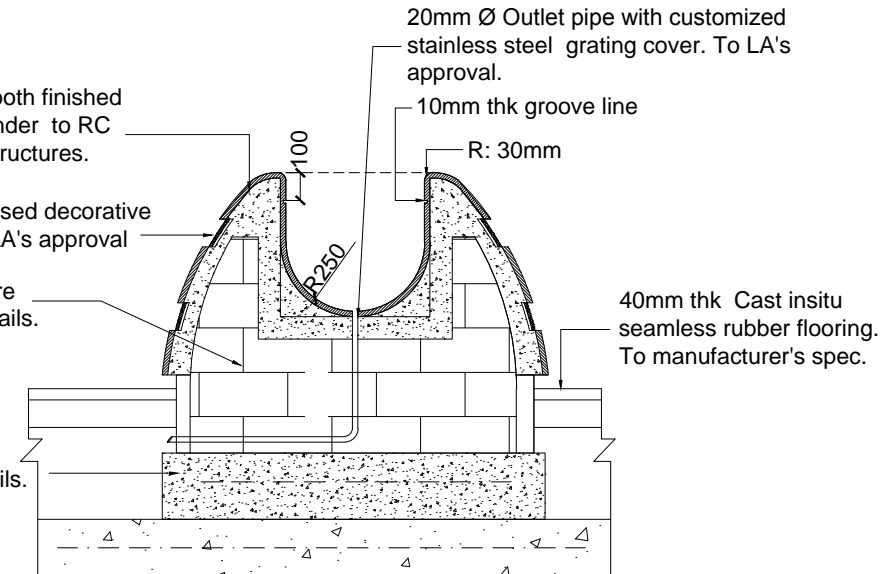

Typical Section

20mm Ø Outlet pipe with customized stainless steel grating cover. To LA's approval.

10mm thk groove line

R: 30mm

40mm thk Cast insitu seamless rubber flooring. To manufacturer's spec.

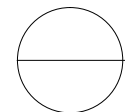

PLAY SCULPTURE EGGS AND EGG CUPS # 2:

Scale 1:30

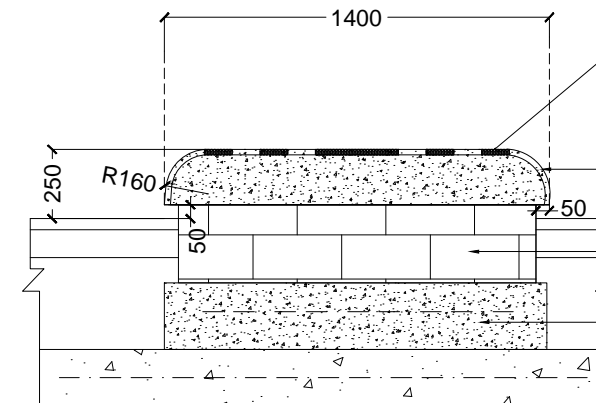

Typical Section

20mm thk decorative mosaic tiles to LA's approval

20mm thick smooth finished white plaster render to RC and brick infill structures.

Brick structure to Engr's details.

Footing to Engr's details.

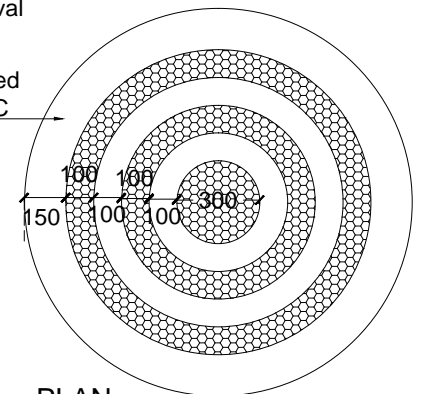

PLAN

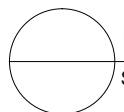

PLAY SCULPTURE EGGS AND EGG CUPS # 1

Scale 1:30

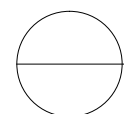

PLAY SCULPTURE : Sand Table

Scale 1:30